

LTX36

SPECIFICATIONS

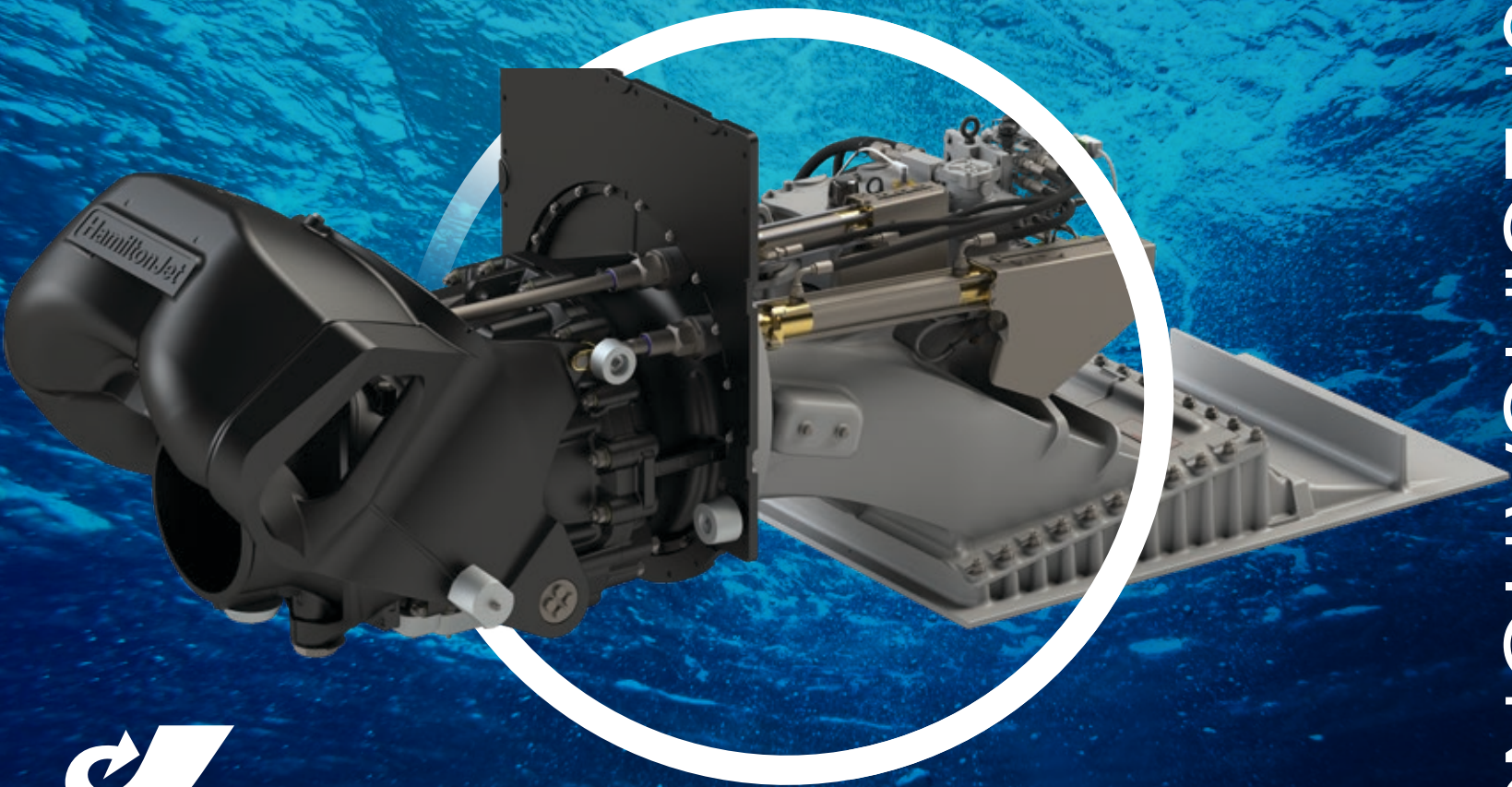

HamiltonJet

The Waterjet Reimagined

LTX36

SPECIFICATIONS

The LTX waterjet is low-speed efficient, lightweight, and lean. With its large nozzle, lower input energy, lower jet velocity, and lightweight structure, this waterjet is designed to rival the performance, energy efficiency and bollard pull of traditional propulsive systems at low to medium speeds.

LTX36 features:

- Power: 310 kW / 416hp (max).
- Max RPM: 1632 rpm.
- Min RPM: 290 rpm.
- Torque: 1885 Nm.
- Speed: up to 30 Knots.
- Jet Weight: 411 kg (dry).
- Entrained water: 110 kg.
- Intake block (Al): 17.6 kg.
- Jet type: Advanced Mixed flow.
- Shaft Rotation – Right Hand.
- Available with AVX controls.
- Enhanced Corrosion Protection.
- Compact Inboard Footprint with fully Integrated Hydraulics.
- Classification: DNV – Others Available on Application.
- New Hydrodynamic Design delivers supremely high efficiency at low to medium speed applications.
- 40% more Peak Bollard Pull and greater sway thrust than other waterjets.
- Low-wear Steering delivers higher precision, minimise performance loss in turns and delivers lower loads at the helm.
- Compatible with all the major electric motors and with a wide range of diesel engines from global manufacturers.

COMPONENT	MATERIAL	STANDARD
Intake Block	EN AC 44100 Cast Marine Grade Aluminium	BS EN 1706
Intake Material	EN AC 44100 Cast Marine Grade Aluminium	BS EN 1706
Stator Material (without LEI)	EN AC 44100 Cast Marine Grade Aluminium	BS EN 1706
Nozzle Material	EN AC 44100 Cast Marine Grade Aluminium	BS EN 1706
Steering Deflector Material	EN AC 44100 Cast Marine Grade Aluminium	BS EN 1706
Astern Deflector Material	EN AC 44100 Cast Marine Grade Aluminium	BS EN 1706
Mainshaft Material	2205 Duplex Stainless Steel	ASTM 276
Wear Ring Material	2205 Duplex Stainless Steel	ASTM 240
Impeller Material	CF8M Cast Stainless Steel	ASTM A743
Anode Material	High Energy Aluminium (Internal and External)	

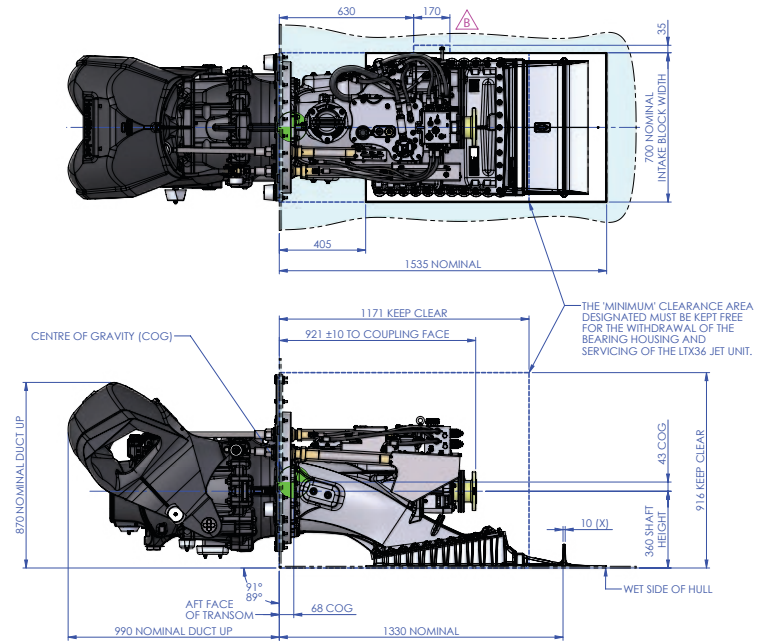

IMPORTANT NOTES: The LTX36 dimensions shown above are Indicative and Preliminary dimensions only for initial design purposes, and subject to change without notice or obligation. Please consult with the factory before using these preliminary dimensions for final installation requirements as these may have changed. Waterjet selection is determined by a range of hull and operational factors, most importantly vessel size and displacement (weight), and not necessarily by matching the above specifications to the desired engine power/RPM curve. In all cases you should consult HamiltonJet for assistance with waterjet selection.

